

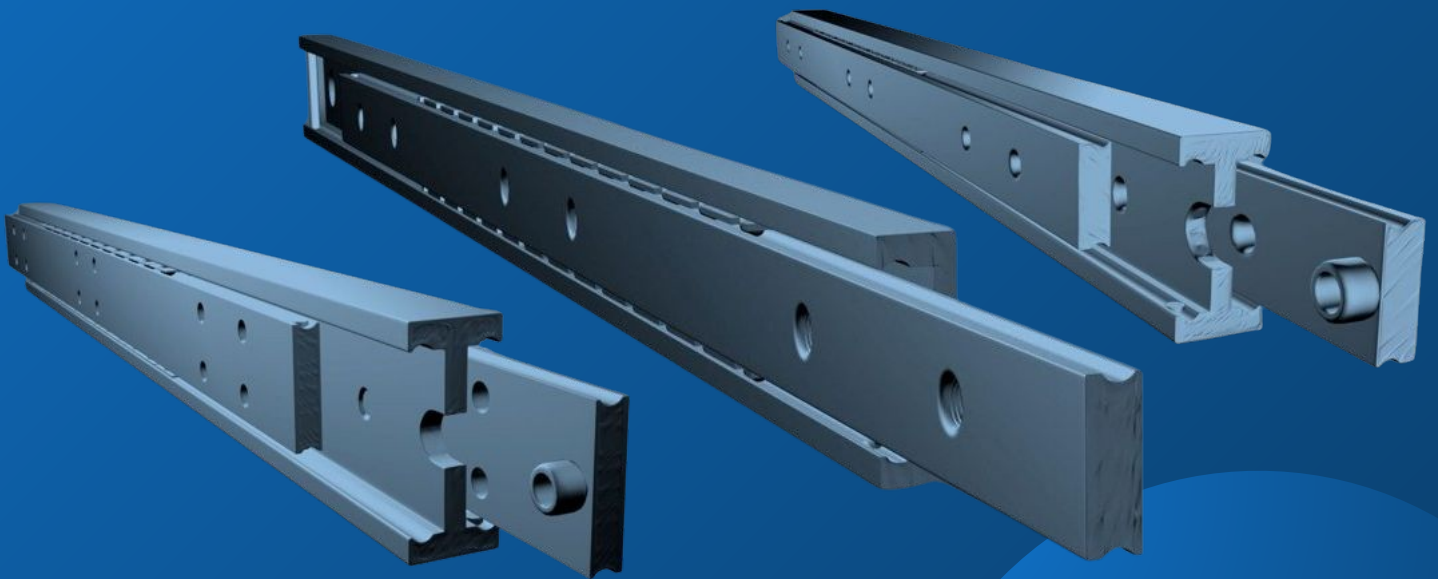

MILUXOR SCHIENEN

German manufacturer of heavy duty rails, telescopic slides and linear guides



High load capacity



Long durability



High resistance



Low maintenance



High smooth running



Precise processing





SLOTS MX-ST 60

The slide combines high load capacity with a small footprint. It remains smooth-running even under high loads.

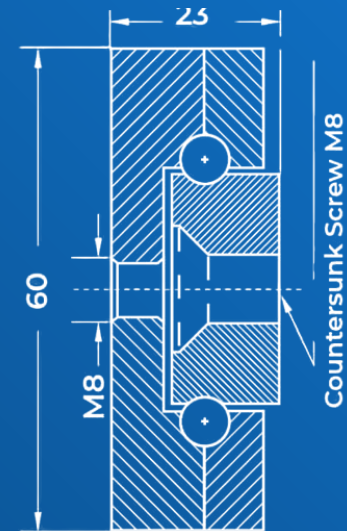

Technical Details

Load capacity	Up to 230 kg per slots
Available installation length	300 up to 3000 mm
Operating temperature	-50 °C up to 280 °C
Corrosion protection	Galvanized (C45)
Material	C45 / stainless steel / aluminum
Track length	Same as installation length
Number of slides	Varies as required
Mounting	According to length & weight M8 countersunk holes
Mounting Slots	2 threaded holes M8 in the center
Maintenance	Low maintenance
Adapted drilling pattern	On request
Customized products	On request





LOAD VALUES AND DRILLING PATTERN

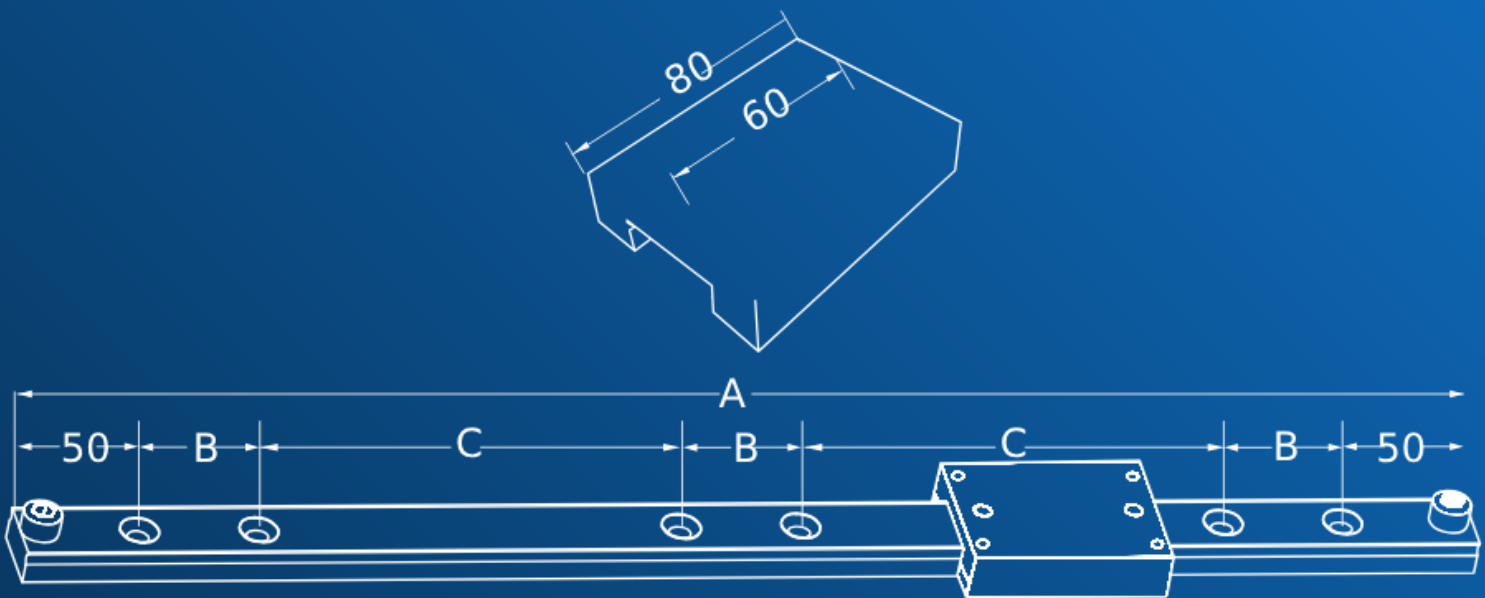

MX-ST 60 Load values table		MX-ST 60 drilling pattern table			
Articel-No.	Installation length in mm	Load in kg*	Dimension A	Dimension B	Dimension C
ST40.030	300	230	300	25	---
ST40	230	...	25	---
ST40.300	3000	230	3000	25	---

* Load per pair in extended position, even weight distribution and vertical installation.





CONTACT UND SUPPORT

Customised offer or questions?

We are always available to help you further. Together we will find a customised solution that is precisely tailored to your requirements / project.

Contact:

Miluxor Schienen GmbH
Kruppstr. 10
36041 Fulda, Deutschland

Phone: +49(0)661 - 9 62 78 28
E-Mail: info@miluxor-schienen.de
Web: www.miluxor-schienen.de

